



West Virginia Tour Application

Return this completed application to West Virginia Humanities Council
Program Officer Kyle Warmack at warmack@wvhumanities.org



The West Virginia Humanities Council (WVHC), the state affiliate of the National Endowment for the Humanities, is sponsoring a special West Virginia tour of ***Crossroads***, an exhibit from the Smithsonian Institution Traveling Exhibition Services (SITES).

The exhibit will travel to six West Virginia communities from August 2021 to June 2022 and is available only through WVHC. Sites will be selected on the strength of their submitted applications including the narrative, appropriate display space, and proposed ideas for local programs and exhibit(s) and geographic location. Selections will be announced on a rolling basis through July and August 2020 until all six available spots have been filled.

Changes have transformed rural America—and West Virginia—throughout the last century. What are some of these changes, and what have they meant for rural life? Why and how do people work to preserve and support their rural communities? What is rural life like today, and how are rural West Virginians shaping their future?

Host institutions are expected to develop a variety of public humanities programs that expand on the themes presented in the exhibit. These might include: lectures, films, and discussions about change within their town or region; interaction with the land; the evolving landscape as the populations of rural towns have grown smaller; the collective identities that motivate them to seek positive transformation of their communities; and more.

The West Virginia Humanities Council invites small museums, historical societies, historic properties, cultural organizations, and communities to apply to host ***Crossroads*** and provide public programs around the exhibit. Organizations in rural areas will receive priority, as the Museum on Main Street program targets rural communities.

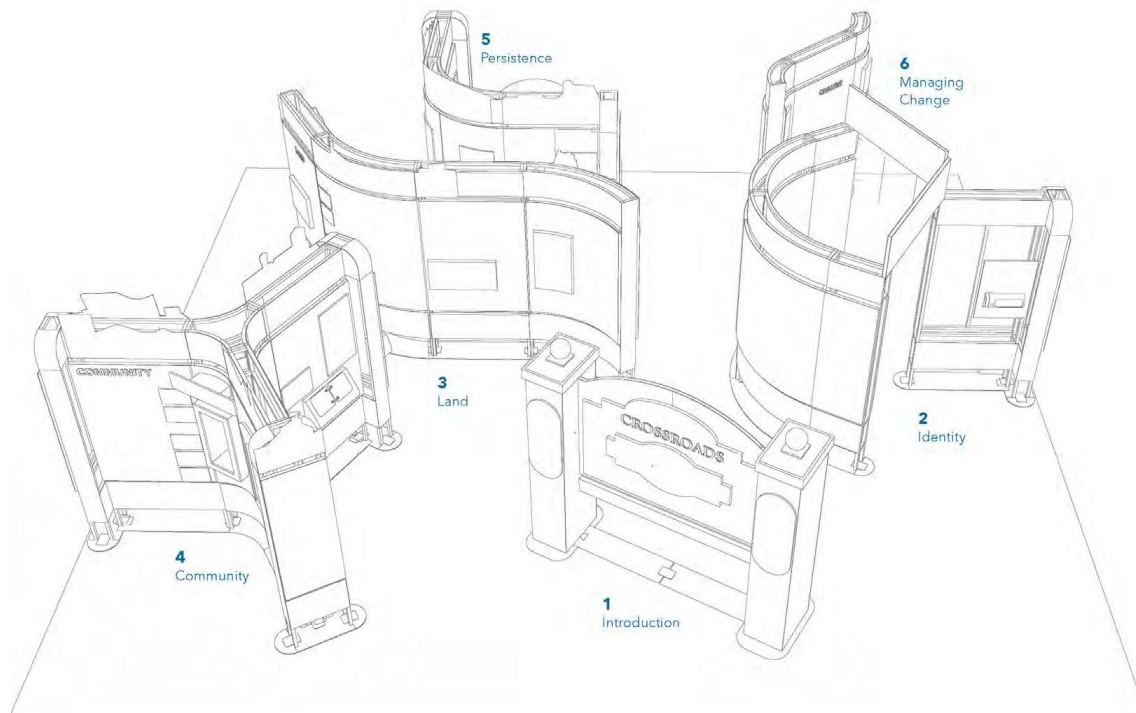

Exhibit Details

The exhibit is organized into six sections, interweaving images and text with video, audio and other interactive elements. By examining the themes of **identity, land, community, persistence, and managing change**, it will present perspectives on the lives of over 60 million people that call rural America home. **Crossroads** offers small towns a chance to look at their own paths, and to highlight the changes that affected their fortunes over the past century. Despite the massive economic and demographic impacts brought on by these changes, America's small towns continue to identify new creative opportunities for growth and development, and many communities have worked tirelessly to create their own renaissance.

Additionally, the exhibit travels with a touchscreen computer component (with an antimicrobial screen). In total the exhibit requires approximately 800 square feet of floor space plus additional space for locally developed exhibit(s). Ceiling height must be at least 8.5 feet tall. Electricity is needed for two video monitors and the touchscreen computer. Audio devices are battery powered. The exhibit ships in 8 large and 8 smaller cases, and is designed to fit into a 26-foot U-Haul truck.

You can visit www.museumonmainstreet.org and www.wvhumanities.org/programs/crossroads





Each selected site receives:

- The exhibit for six weeks. WVHC pays the rental fee of the exhibit for the host.
- Up to \$3,000 to help implement and publicize locally developed programs and exhibits. These funds do not require a cash match but must show in-kind match such as staff/volunteer time spent in planning and implementing the project, materials/supplies contributed, donated goods or services, etc. **Additional funds are also possible for larger projects related to the exhibit by applying through the council's competitive grants program.**
- Printed and online exhibit how-to guides for installation, program planning, fundraising, developing local displays and public relations.
- Educational materials including brochures, online lesson plans, and docent training guide.
- Exhibit promotional materials including posters, brochures, outdoor banner, postcards, and complete press kit.
- WVHC assistance with planning local humanities-based programming.
- A tour scholar to help develop programs/displays and to give a presentation at your display site.
- National and in-state support materials and inclusion in national and statewide publicity efforts.
- Travel/lodging assistance for project personnel to attend statewide planning meetings.



Each selected site agrees to:

- Identify and provide a staff member or volunteer to serve as the project director for its duration and attend planning meetings as needed including a planning session and an installation workshop at the first tour site.
- Plan and implement humanities-based public programs based on the ***Crossroads*** theme.
- Create a companion exhibit that builds on the ***Crossroads*** theme as it relates to the town's or region's rural identity.
- Consult with WVHC Program Officer and state tour scholar to confirm appropriate humanities content for supplemental programs and exhibits.
- Coordinate transport of the exhibit with the WVHC Program Officer *to* their display site *from* the previous site.
- Communicate regularly with WVHC Program Officer concerning planning, programming, and reporting. Email is the primary means of communicating with selected sites. Selected sites will have a regularly checked email address.
- Provide adequate people to safely set up and take down the exhibit.
- Form and regularly convene a committee composed of organization members and community representatives to help plan and implement programs, displays, promotion, installation, and reporting.
- Submit to WVHC and the tour scholar an advance schedule/calendar of programs, and a listing of any sources of funds and/or donated services and materials related to the exhibit.
- Complete all necessary paperwork required by WVHC and SITES and keep a general accounting of all local cost share (cash, goods and services) donated for this project.
- Maintain regular and widely publicized exhibit hours during the display period so the public can attend. Venues that maintain "By Appointment Only" hours will not be considered, unless they revise that policy for the duration of the exhibition.

APPLICATION

Return this completed application to West Virginia Humanities Council
Program Officer Kyle Warmack at warmack@wvhumanities.org

Please tell us about your institution/organization. (Please type or print clearly.)

HOST ORGANIZATION

Host Organization: _____

Address: _____

City, Zip: _____

Phone: _____ Fax: _____ Email: _____

HOST VENUE

Site/Venue where the exhibit will be displayed: _____

Address of venue: _____

Does the site have handicapped access? _____

The following requirements are necessary to host **Crossroads**. Please check the boxes below to verify that your venue possesses these elements:

Access ramp or freight elevator to exhibit space (if space is not at ground level)

Venue doors are minimum 82" tall (to accommodate large crates)

Exhibit space can be locked and secured after hours

PERSONNEL INFO

Project Director/Title: _____

Project Director email: _____ Phone #: _____

Number of Permanent Staff Full Time: _____ Part Time: _____

Number of Regular Volunteers: _____

Number of volunteers/staff projected to assist with *Crossroads* exhibit: _____

Approximate Annual Visitation to Venue: _____

Days / Hours of Operation: _____

Population of your Community: _____

What days/hours will *Crossroads* be open to the public? _____

Please list three dates before August 31 that would be most ideal for a visit from the WVHC Program Officer, in order of preference: 1._____ 2._____ 3._____

Please complete the following. If you need additional space, please attach an additional PDF or Word document to your application with the questions clearly numbered:

1. Briefly describe your facility and the display space. *Crossroads* is approximately 800 square feet. Remember you also need space for your companion exhibit(s) and supplemental programs.

2. Why will your venue be a good display site for *Crossroads*? Focus on the advantages of the space itself—we'll cover programs and partners in later questions.

3. Please give three or four examples of the type of public programs/events or exhibits your organization has presented in the past three years.

4. What are a few interpretations of the rural experience that you might pursue through an exhibit or a public program? We expect selected sites to embrace the challenge of the humanities and explore not only local history, but also what rural life means to different kinds of people and what it says about us as individuals, communities, and human beings.

5. Identify at least two rural stories you would like to tell about your town or region through this project.

1.

2.

6. What type of companion exhibit(s) could you develop to tell the story of your local sports tradition? What community resources can you tap for your local exhibit(s)?

7. What resources in your community (*organizations, clubs, schools, teams, leagues, museums, businesses, individuals, facilities, alumni associations, historical societies, libraries, employers, etc.*) might participate or contribute to the success of this project? Please name at least 3. Identify groups that will participate in the project and what their role will be. Collaboration is encouraged to build broad community involvement in the project. Include letters of support from participating groups if possible.

Please note your first, second, and third choices for the ***general display periods in 2021-2022*** you could host ***Crossroads***. Please note that you might not get your first choice. Dates listed are **not final** and will be adjusted once the final roster of venues is complete.

___ **August 28 – October 9, 2021**

___ **October 16 – November 27, 2021**

___ **December 5, 2021 – January 16, 2022**

___ **January 23 – March 6, 2022**

___ **March 13 – April 24, 2022**

___ **May 1 – June 12**

Are there any other scheduling considerations you would like us to be aware of at your venue?